

INFLUENCES OF PD LOCATION AND FREQUENCY RANGES ON MEASURED APPARENT CHARGES

Anne Pfeffer^{1*}, Stefan Tenbohlen¹ and Stefan Kornhuber²

¹Institute of Power Transmission and High Voltage Technology, Pfaffenwaldring 47, 70569 Stuttgart, Universität Stuttgart, Germany

² Doble Lemke GmbH, Zschoner Ring 9, 01723 Kesselsdorf, Germany

*Email: anne.pfeffer@ieh.uni-stuttgart.de

Abstract: The reliability of electrical energy networks depends on the quality and availability of electrical equipment like power transformers, cables or GIS. Local failures inside their insulation may lead to catastrophic breakdowns and can cause high outage and penalty costs. To prevent these destroying events power transformers are e.g. tested on partial discharge (PD) activity before commissioning and currently also in service. The conventional measurement of the apparent charge of PD according to IEC 60270 [1] picks-up signals with a high voltage coupling capacitor. This method is commonly used for quality assurance of high voltage equipment. This paper deals with the influence of PD location and the measurement frequency ranges on the measured apparent charge. Therefore, measurements on a movable PD source with constant geometry and measuring set-up were performed [2]. The differences of the IEC 60270 broadband measurement and measurements in higher frequency ranges (up to 4.5 MHz) are tremendous because the winding behaves like a low pass filter and the PD signals in higher frequency ranges are damped. Additionally a multi-terminal measurement was performed and shows the effect on the Star Diagram [3] of a measurement in higher frequency ranges.

1 INTRODUCTION

Defects in transformer insulation cause partial discharges (PD), which can progressively degrade the insulating material and can possibly lead to electrical breakdown. Therefore, early detection of partial discharges is important. PD measurements can also provide information about the ageing condition of transformers and thus enable conclusions about their lifetime.

The conventional measurement of the apparent charge of PD according to IEC 60270 [1] and signal decoupling with a high voltage capacitor are common measurement technologies for quality assurances of high voltage (HV) equipment. According to IEC 60270 the measurement setup can be calibrated in terms of pico Coulomb (pC). The measurable apparent charge in terms of pC has no direct relation to the real charge within the PD. Nevertheless threshold values of the apparent charge levels for acceptance test after manufacturing of new power transformers proofed to be successful since recent years.

Performing the same calibration process in field, PD measurements on-site should have the same sensitivity in terms of pC. But no standardised threshold values for the apparent charge are valid or at least accepted for aged transformers which are tested again for PD activity in field. The evaluation of insulation condition is discussed in case of any measured PD activity.

Because of an integral calculation of the apparent charge, the standard IEC 60270 measurements are supposed to be independent of the

measurement setup and also on the location of the PD source at least after calibration. The current paper deals with that misunderstanding of the IEC 60270 measurements and gives further proof, that focusing only on the apparent charge is not helpful, because the measurable apparent charge depends normally on the unknown location of the PD source in the winding. Also for on-site measurements higher frequency ranges up to 1 MHz are used to remove the noises of lower frequencies, e.g. corona of busbars. The paper presents the differences of the sensitivity depending on the frequency range according to IEC 60270 or with higher measurement frequencies used for onsite measurements.

2 MEASURING SET-UP

The main part of the PD source is a typical HV disc winding, as used in oil-insulated transformers. The winding is on HV potential and not grounded, which means that each turn is on the same potential. For that arrangement the winding is free of PD up to a measurement voltage of 35 kV.

For the generation of PD a grounded metal sheet core is positioned inside of the winding. This core reproduction has also a vertical bearing inside of which an aluminium cube can be moved in vertical direction. For this purpose the cube is mounted on a threaded control rod, which changes the position of that cube by being rotated, as shown in Figure 1.

The mechanical dimensions of the winding lead to possible locations of the PD source in a vertical range of 0 mm - 800 mm. A PD source location of 0 mm indicates the highest possible position within

the winding, whereas a value of 800 mm implies that the PD source is at the bottom of the winding. An Ogura needle [2] is mounted on that moveable cube perpendicularly to the surface of the grounded sheet core. At the tip of the grounded needle (tip radius $r_p = 3 \mu\text{m}$), occurs a field enhancement of the electric field, when the winding is connected to HV potential. This field enhancement leads to the generation of PD (internal corona) at measurement voltages of higher than 25 kV. Thus it is possible to generate PD along the inner surface of a HV winding over its entire depth, without changing the electrode geometry of the PD source.

By varying the location of the PD source location there is no change in its geometry, but there is a significant change in the PD source impedance. Each single winding consist of a series inductance L_S , parallel capacitances to the tank surface and sheet core (concentrated to C_A) and capacitances to the other windings (C_W), see Figure 2.

At the highest position of the PD source, e.g. 0 mm, the series inductance (L_S) is at its lowest value. At the moment of a PD, represented by the switch in Figure 2, its discharge current (sourced by C_A and C_K) flows through a parallel circuit of L_S and C_W . At a PD source position lower in the winding, e.g. 800 mm, the discharge current has to flow through a series network consisting of a number of parallel circuits of L_S and C_W . The series inductances are added linearly, whereas the sum of the winding capacitance decreases in value. Thus the high-voltage winding has a filtering effect on the PD discharge current and influences the results of electrical PD measuring systems.

The HV winding, including the PD source, is placed into a cylindrical transformer tank, which is filled with mineral oil. The tank is connected to the metal sheet core and both are grounded via copper bands to the main ground. The HV winding is connected to a HV AC source and a parallel coupling capacitor ($C_K = 2.5 \text{ nF}$) according to the test circuit stated in IEC 60270. The coupling quadrupole (Z_m) is inserted between the low potential side of the coupling capacitor C_K and ground. The quadrupole has two output ground ports, one to measure the test voltage and another for the PD signal.

That PD-output has a band-pass behavior within a range of 15 kHz to 15 MHz. The calibration process according to IEC 60270 was performed by injecting calibration impulses at the top of the winding outside the tank. A change in the PD source position did not influence the value of the apparent charge of the recorded calibration impulses. A change of the frequency influences the apparent charge enormously. Therefore, a calibration is affordable when the measurement frequencies were changed.

Two DN80 flanges of the used transformer tank allow the installation of two UHF-sensors [3]. These sensors detect the electromagnetic

emissions of PD pulses, without influencing the electric measurement circuit according to IEC 60270.

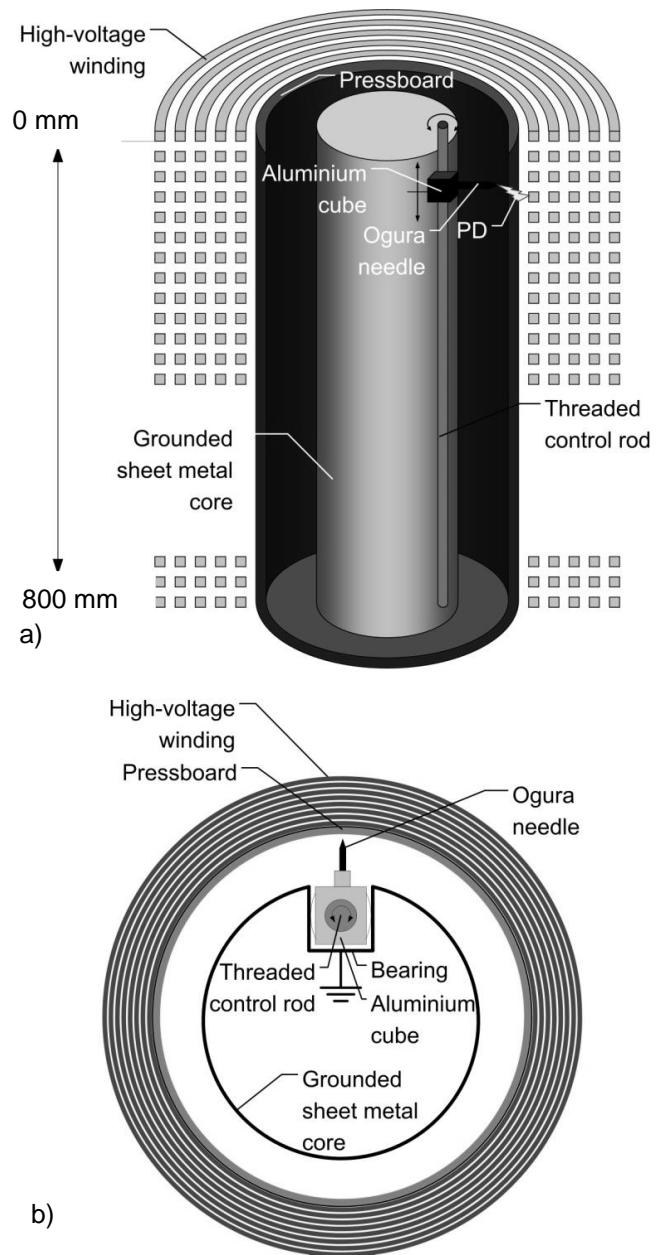

Figure 1: PD source construction inside a HV disc winding: a) vertical view, b) top view

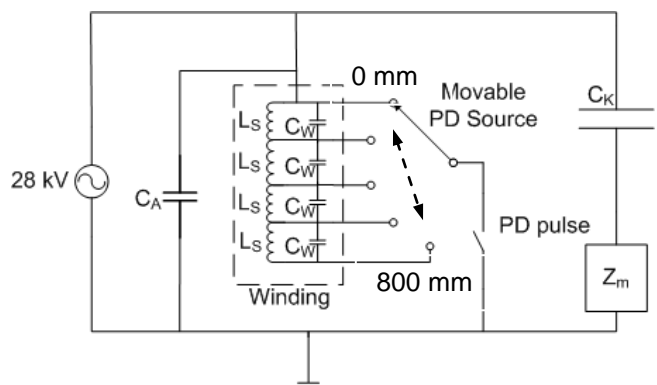
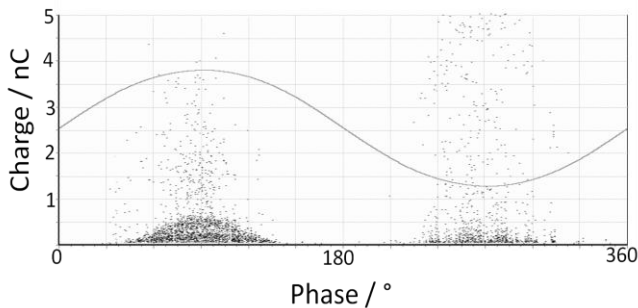

Figure 2: Equivalent circuit of movable PD source

3 CHANGE OF APPARENT CHARGE DEPENDING ON PD LOCATION AND FREQUENCY BAND

For on-site measurements the frequency range of the broadband measurement system according to IEC 60270 ($f_c = 100 - 900$ kHz, $\Delta f = 300$ kHz) are extended to reduce the noise. Sometimes measurements are performed with frequencies up to several MHz. Figure 3 shows the PRPD pattern of three positions, 0 mm, 100 mm and 200 mm of the movable PD source. The measurements were performed in the IEC 60270 conform frequency range, with a centre frequency of $f_c = 250$ kHz and bandwidth $\Delta f = 300$ kHz. The detected PDs remain constant in terms of phase angle, but the activity of the PD increases with deeper position of the PD source. The maximum level of the PD is 5 nC in all three positions. All measurements were performed at test voltages of 28 kV.



a) Position of PD source: 0 mm, 1112 PDs in 90 sec

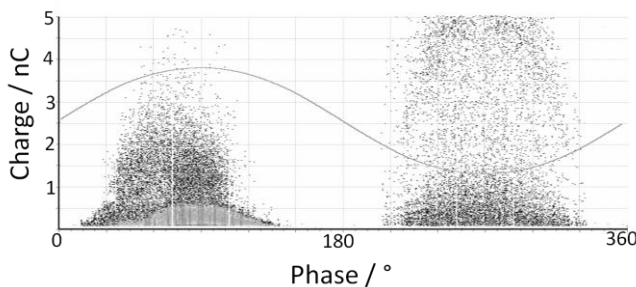

b) Position of PD source: 100 mm, 20610 PDs in 90 sec

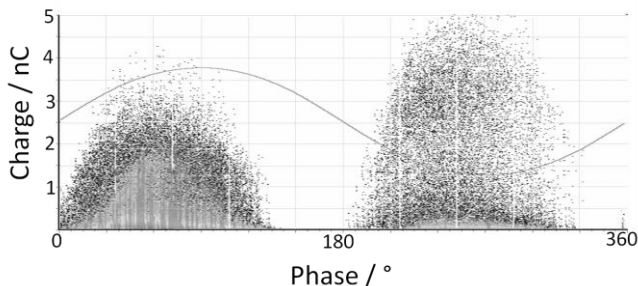

c) Position of PD source: 200 mm, 66187 PDs in 90 sec

Figure 3: PRPD patterns at test voltages of 28 kV and changing PD source locations, $f_c = 250$ kHz and $\Delta f = 300$ kHz

According to the measurements the PD of this source are build out of two pulses with different frequency ranges, see Figure 4 and 5. On the one hand there is a high frequency pulse of approx. 2.5 MHz in the positive half cycle of the test voltage and on the other hand there is a low frequency pulse of approx. 100 kHz in the negative half cycle. Analyzing the pulses in detail, it can be shown that the low frequency pulse is mainly linked with the phasing of the test voltage between 180° and 290° and the high frequency pulse is located on the phasing of the test voltage between 0 and 110° .

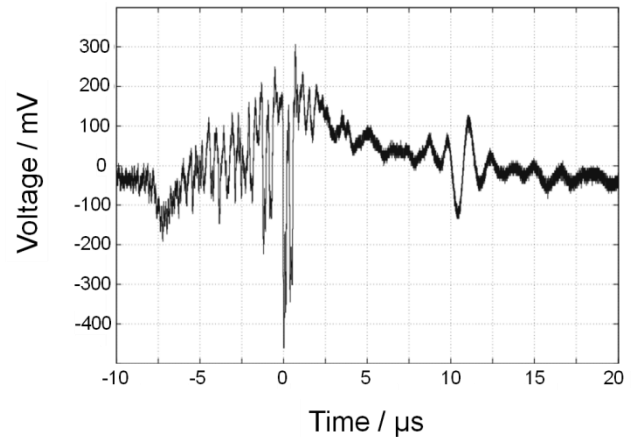

Figure 4: Typical PD Impulse of the first quadrant with a phasing of $\phi = 108^\circ$, test voltage $V_{test} = 28.8$ kV and PD source position 0 mm

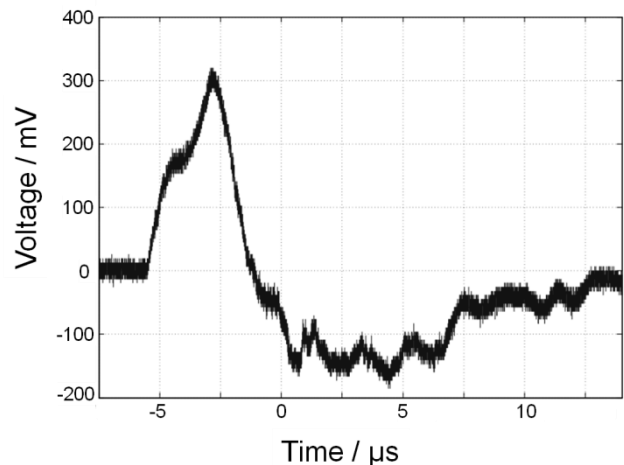

Figure 5: Typical PD Impulse of the third quadrant with a phasing of $\phi = 269^\circ$, test voltage $V_{test} = 28.8$ kV and PD source position 0 mm

Figure 6 shows a measurement setup to verify the filtering of PD-pulses injected in a transformer winding. The setup consists of a coupling capacitor (C_k), the transformer winding of the height (h) with the measuring points (MP), a pulse Generator (PD calibrator) and a 2.5 GS/s oscilloscope.

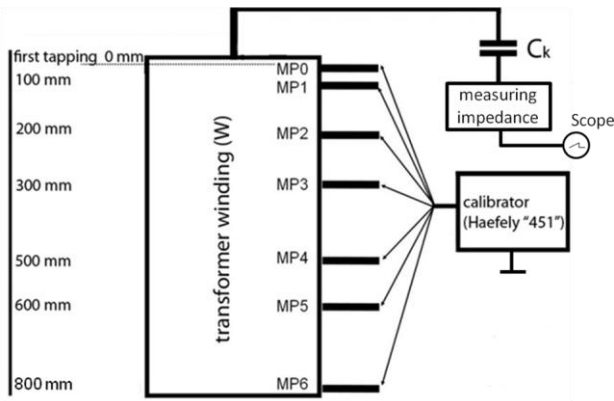

Figure 6: Measurement setup showing the locations where the calibrator impulses are injected in the winding

The pulse generator is normally used in HV test-fields to calibrate a PD measurement according to IEC 60270 and generates reference PD pulses while activated. Starting at the top of the winding the pulses are injected in the winding at several MP. The oscilloscope is recording the pulses and stores the data for later signal evaluation, e.g. FFT.

Considering the attenuation characteristics of the winding including the oil tank and the complete IEC measuring setup we can expect some major problems in measuring the PD events with high frequency electrical measurements.

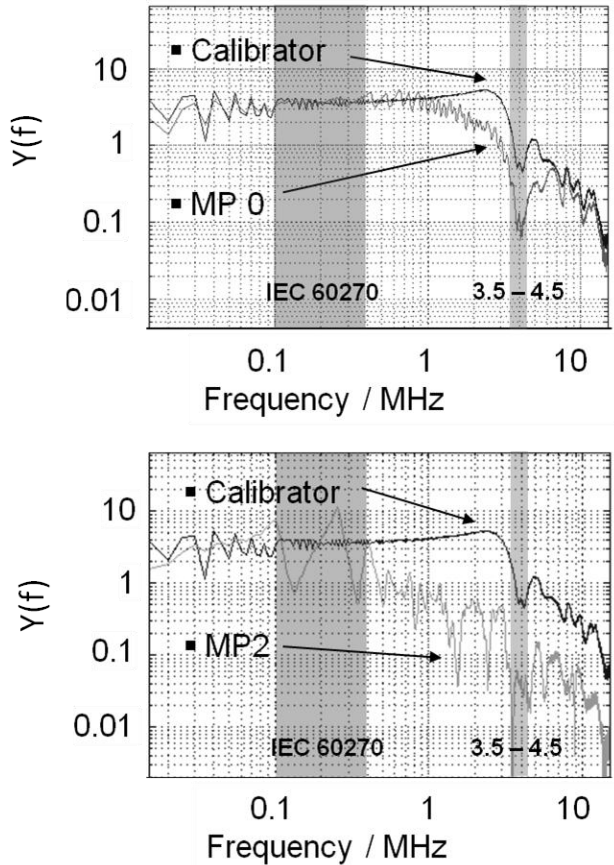
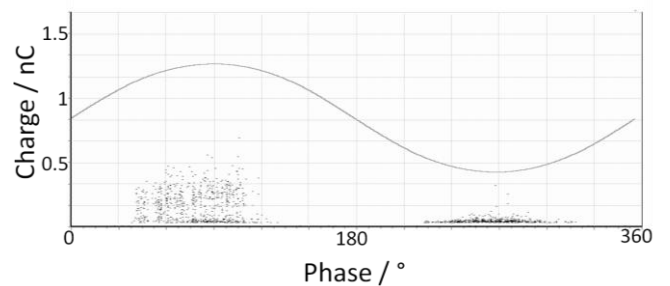
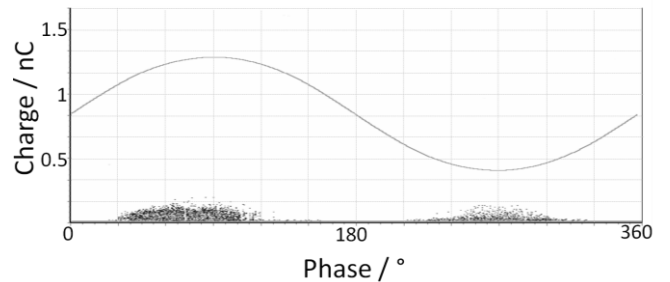

Figure 7: FFT of calibrator impulses applied on different measurement points

Figure 7 shows the calculated FFT of the measured signals of the same calibrator impulses on different measuring points. The first shaped area is the IEC broadband frequency domain and the smaller shaped area is the higher frequency domain (3.5 - 4.5 MHz). The comparison of the two areas of the spectral magnitudes shows that an electrical measurement done at e.g. centre frequency $f_c = 250$ kHz with a bandwidth of $\Delta f = 300$ kHz will lead to more sensitive data, because of the lower damping characteristic of the calibrator impulses on deeper PD positions in frequency ranges up to 1 MHz. Therefore, more accurate patterns can be measured in the IEC 60270 defined frequency ranges, than in any other higher frequency range as long as there is no corona or other environmental disturbance.



a) Position of PD source: 0 mm



b) Position of PD source: 100 mm

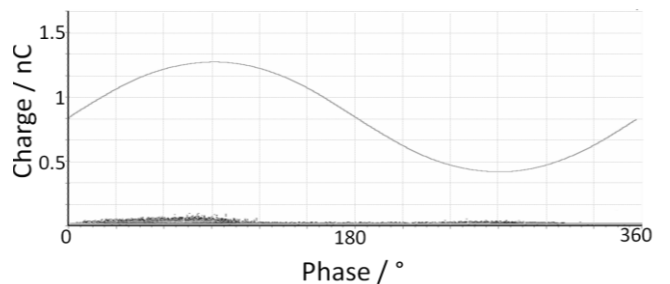

c) Position of PD source: 200 mm

Figure 8: PRPD pattern at test voltages of 28 kV and changing PD source locations, $f_c = 4$ MHz and $\Delta f = 1$ MHz

Shifting the measurements to higher frequencies will result in decreasing PD events and finally to no detection of any PD events. In this case the only way to detect proper events and constant PD

levels is to do any electrical measurements below the effective cut-off frequency of approx. 1 MHz of the complete measurement setup.

In Figure 8 the measurements in a higher frequency range, centre frequency $f_c = 4$ MHz and bandwidth $\Delta f = 1$ MHz, are shown. The detected PDs remain constant in terms of phase angle, but decrease in amplitude in terms of pC by increasing depth of the PD source. E.g. at a source position of 0 mm the recorded PD have a maximum amplitude of about 900 pC, decreasing to 100 pC maximum at a source position of 200 mm (PD of positive half cycle). The PD impulses in the negative half cycle are not measurable in deeper positions because their apparent charge levels are the same height as the noise level. After the first few windings the higher frequencies of the PD events are fading to zero because the measurement setup with the winding forms a low pass filter for the PD impulses as shown in Figure 7.

This phenomena possibly leads to problems in the pattern analysis, as the PRPD pattern of a source location of 0 mm indicate a high field enhancement at a grounded tip (inner corona) [4]. The pattern originating from the same PD source at a position of 500 mm contrarily fit rather to inner corona of a high potential tip, with lower electrical field strength. As the geometry of the PD source does not change, there should be no change in the real charge over the source location.

The IEC 60270 setup cannot resolve if the change of measurable apparent charge is caused by a change of the PD source pulses or by different coupling impedance based on another PD location. Simultaneously measured UHF signals indicated that the PD pulses of the PD source were constant over the entire depth, because the UHF radiation of the PD source did not change significantly. Due to that the changed impedance, as explained with Figure 2, was responsible for the filtering or damping effect of the measurable apparent charge of the PD source.

Calibration procedure according IEC 60270 is not able to adopt with that phenomena because calibration pulses are only injected outside the winding, e.g. on the bushings of transformers. The changing winding impedance by changing PD location is not taken into account and even the idea to deal with that phenomenon by integration of the current impulse of PD seems not to work for all practical cases.

The results were verified with an acoustic method to localise the PD source. As acoustic trigger the UHF signal of the UHF probe were used [5].

4 SIMULTANEOUS MULTI-TERMINAL MEASUREMENTS

The multi-terminal PD measurement bases on the standard measurement circuit of the IEC 60270. For PD measurement on power transformers a three phase measuring system is used. Evaluation of multi-terminal PD measurements establishes a straight forward approach to distinguish between multiple PD and noise sources.

The multi-terminal measurement is illustrated in a STAR diagram [2]. The STAR diagram is a two-dimensional plot with a 120° phase shift of the three phase axis. Figure 9 shows the impulse signals on all phases of a single PD event. E.g. the PD source is located on phase L_1 and the PD signals of phase L_2 and L_3 occur because of cross-talk in the windings. The addition of the signal amplitude vectors of a single PD activity (value in pC) measured at the three phases resembles in a point in the diagram. In this example the point is close to L_1 indicating that the PD source is located in phase L_1 .

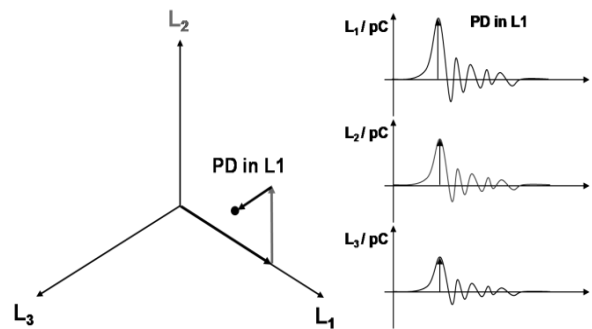

Figure 9: STAR diagram evaluation of the PD impulse signals of a three phase measurement

A three phase measurement setup was used to measure the influence by changing the frequency ranges on all three phases. The calibration was repeated with every change of the measurement frequency. The PD source was a internal corona configuration in mineral oil and was located on phase L_3 . Phase L_1 and L_2 were not directly connected to the PD source.

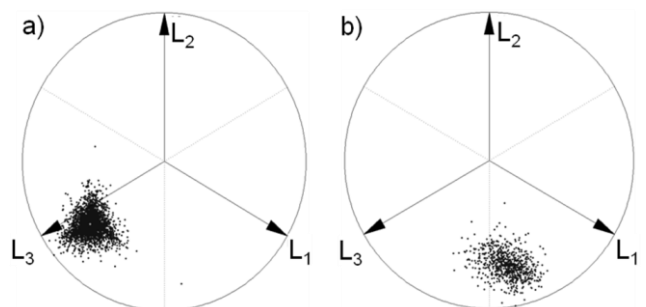

Figure 10: STAR diagram of a PD source on L_3 ;
a) frequency range of L_1, L_2, L_3 : 100 - 400 kHz
b) frequency range of L_1, L_2, L_3 : 950 - 1500 kHz

In Figure 10 the results of STAR diagrams of two measurements with different frequency ranges are shown. The frequency ranges of all three phases were IEC conform, i.e. 100 kHz to 400 kHz. For the next measurement the frequency ranges were changed to 950 - 1500 kHz for all three phases.

The effect of changing the measurement frequency is tremendous. The PD level in pC increased for higher frequency ranges on phase L₁ in contrast to phase L₃ and L₂. Therefore the interpretation of the PD failure position is inaccurate for Figure 10 b). Though the influence of the frequency range on multi-terminal measurements is enormous and the results are not comparable.

5 CONCLUSION

A movable PD source inside a HV winding allows measuring the influence of PD location on PD measurement results. The test results show a high damping effect of the winding on the apparent charge, measured with the test circuit according to IEC 60270 with frequency ranges up to 1 MHz, see Figure 8.

The measured apparent charge and the activity of the PD depend on the PD location inside the winding. That effect was proofed with a commercial PD measurement system as well as with a measuring setup using an oscilloscope. The FFT of measured calibrator impulses through the winding showed the damping characteristic of the winding. The frequency range of up to 1 MHz has an enormous influence on the measured levels in terms of pC.

Parallel UHF measurements indicate that the PD source properties did not change. The effect of the PD level in terms of pC is affected by the low pass filtering of the winding. The PD source location was additionally detected with an acoustic measurement to verify that the measured PD signals belong to the point-plate PD source.

The multi-terminal measurement with different frequency ranges showed also an effect on the result of the STAR diagram. With higher frequency ranges it is possible that different pC levels on all three phases can occur. So the STAR diagram totally changes, see Figure 10. These levels depend on the different spectral components of the complete measurement setup. The changes in stray capacitances and inductances of all three phases can be responsible for those effects. Therefore a correlation between the STAR diagram and the real position of the PD is no more present.

6 REFERENCES

- [1] IEC 60270 High voltage test techniques – Partial discharge measurement
- [2] S. Coenen, S. Tenbohlen, S. Markalous: "Influence of PD Location in Transformer windings on IEC 60270- and UHF-Measurements", CMD, Tokyo, 2010.
- [3] A. Pfeffer, S. Coenen, S. Tenbohlen, Sacha. M. Markalous, T. Strehl: "Onsite experiences with multi-terminal IEC PD measurements and UHF PD measurements", Proceedings 17th ISH, Cape Town, South Africa, 2009
- [4] Jitka Fuhr, "Procedure for Identification and Localization of Dangerous PD Sources in Power Transformers", IEEE Transactions on Dielectrics and Electrical Insulation, Vol. 12, No. 5, pp. 1005-1014
- [5] S. M. Markalous, "Detection and Location of Partial Discharges in Power Transformers using Acoustic and Electromagnetic Signals", Ph.D. Thesis (Dissertation), Universität Stuttgart, 2006.